

ELEVATION

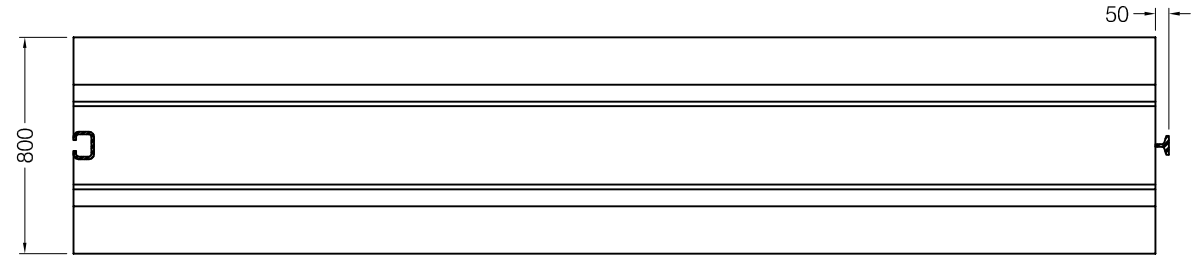

PLAN

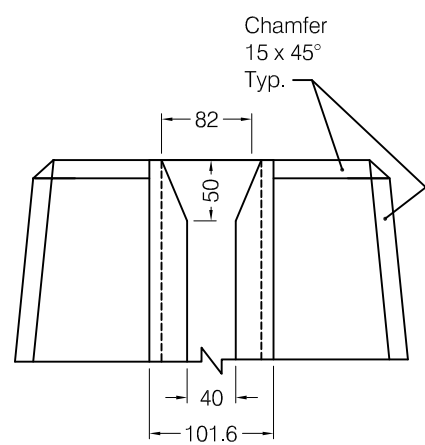

DETAIL A

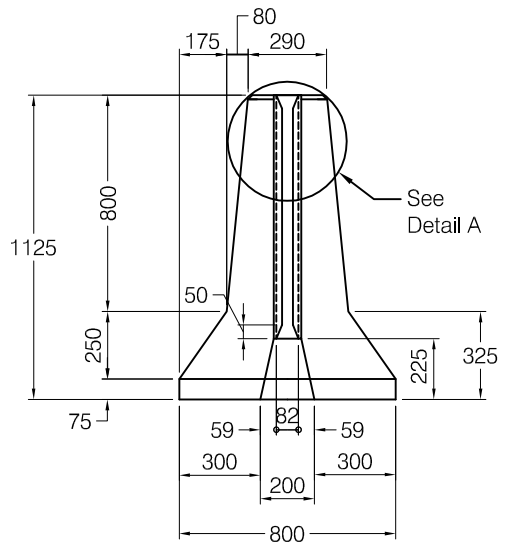

END VIEW DETAIL FEMALE CONNECTOR

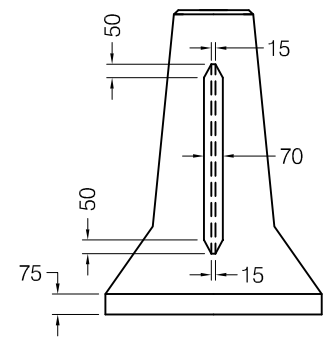

END VIEW DETAIL MALE CONNECTOR

- Notes:
- Manufactured in accordance with:
 - OPSD 911.143
 - OPSS 1350
 - OPSS 1352
 - Special Provision No. 740S06
 - Reinforcing as per OPSD 911.143
 - Concrete strength: 40 MPa @ 28 days min.
 - Concrete cover 50mm minimum.
 - Drawing refers to precast component only.
 - Weight - 5,000 kgs
 - All dimensions in millimetres unless otherwise noted.

DWG. No. M CON 911.143

TOLERANCE: AS PER SPECIAL PROVISION 740S06		NOTES: MIN CONC STRENGTH: 35 MPA CONC STRIPPING STRENGTH: 20 MPA CLEAR COVER: 50MM MIN. MIX DESIGN NO. 45 IN COMPLIANCE WITH: SP NO. 740S03	
ALL DIMENSIONS ARE IN MM UNLESS OTHERWISE NOTED			

MCON PIPE & PRODUCTS STANDARD DRAWING

STD: OPSD - 911.143 PRODUCT CODE:

TITLE:
**PRECAST CONCRETE BARRIER
I-LOCK CONNECTION - TALL WALL
OPSD 911.143 - 4.0M LENGTH
PERMANENT INSTALLATION**

REV	DESCRIPTION	ENG	DATE
A	INCREASED BASE FROM 50MM TO 75MM	SK	04-02-14
B	MIX DESIGN CHANGED TO NO. 45	SK	04-02-14

DRAWING BY: S.K.	CHECKED BY: S.K.	DATE JUNE 9TH 2012	FILE	PAGE 1 OF 1
---------------------	---------------------	-----------------------	------	----------------



PO Box 1191
2691 GREENFIELD ROAD AYR, ONTARIO NOB 1E0 FAX 519-632-7440

TEL 519-632-9112
866-537-3338